



**WACKER
NEUSON**
all it takes!

Operator's Manual

Rammer

BS-2



Machine Type	BS50-2, BS60-2, BS70-2
Material Number	5100056271
Version	3
Date	07/2022
Language	[en]



5 1 0 0 0 5 6 2 7 1

Imprint

Publisher and copyright holder:

Wacker Neuson Produktion GmbH & Co. KG

Wackerstraße 6

85084 Reichertshofen, Germany

Registered office: Reichertshofen

Register court and number: Local Court Ingolstadt, HRA3195

VAT ID No./VAT Number: DE277138620

Telephone: +49 (0) 8453-3403200

www.wackerneuson.com

Original operator's manual

All rights reserved, in particular the copyright, the right of reproduction and the right of distribution applicable worldwide.

This document may be used by the recipient only for the designated purpose. It may in no way be duplicated or translated in any other language, in whole or in part, without prior permission in writing from the manufacturer.

Reproduction or translation of this publication, in whole or part, is not permitted without the written consent of Wacker Neuson Produktion GmbH & Co. KG.

Violations of legal regulations, in particular of the copyright protection, will be subject to civil and criminal prosecution.

Wacker Neuson Produktion GmbH & Co. KG reserves the right to change its products and their technical specifications for further technical development at any time without any claim to changes to machines already delivered. The information in the technical documentation supplied with the product applies in each case.

The machine on the cover is for illustration purposes only and may therefore have special equipment (options).

Wacker Neuson Produktion GmbH & Co. KG, responsibility for errors or omissions not accepted, printed in Germany

Copyright © 2022

Contents

1	EC Declaration of Conformity	
2	Foreword	
2.1	Introduction	9
2.2	Storage Location of the Operator's Manual	9
2.3	Accident Prevention Regulations	10
2.4	Contact person	10
2.5	Limitation of liability	11
2.6	Use of the operator's manual	11
3	Usage	
3.1	Designated use	12
3.2	Unintended use	12
4	Safety	
4.1	Safety symbols and signal words	13
4.2	Principle	13
4.3	Structural changes	14
4.4	Responsibility of the operator	14
4.5	Obligations of the operator	15
4.6	Qualification of staff	15
4.7	General safety instructions	15
4.8	Specific rammer-related safety instructions	17
4.9	Safety features	18
4.10	Maintenance	19
5	Description of the Machine	
5.1	Type plates and labels	22
5.2	Components	24
5.3	Control elements	25
6	Transportation	
6.1	Safety instructions for transport	26
6.2	Prerequisites and preparations	26
6.3	Lifting the machine	26
6.4	Lashing the machine	27
7	Commissioning	
7.1	Safety instructions for operation	28
7.2	Tests before commissioning	29
7.3	Putting into operation	29
8	Operation	
8.1	Operating the machine	31
8.2	Select speed	32

8.3	Taking the machine out of operation.....	32
9	Maintenance	
9.1	Safety instructions for maintenance.....	33
9.2	Maintenance plan.....	34
9.3	Maintenance work.....	35
10	Troubleshooting	
10.1	Troubleshooting.....	43
11	Shutdown	
11.1	Temporary decommissioning.....	44
11.2	Final shutdown.....	44
12	Accessories	
12.1	Accessories.....	45
12.2	Transport roller installation.....	46
13	Technical Data	
13.1	General instructions.....	47
13.2	Noise and vibration data.....	47
13.3	BS.....	47
13.4	Combustion engine.....	51



**WACKER
NEUSON**
all it takes!

EU Declaration of Conformity

Manufacturer

Wacker Neuson Produktion GmbH & Co. KG, Wackerstraße 6, 85084 Reichertshofen (DE)
This declaration of conformity is issued under the sole responsibility of the manufacturer.

Product	BS50-2
Product type	Vibratory rammer
Function of product	Soil compaction
Material number	5100030590, 5100030591, 5100030594, 5100030595, 5100030596, 5100058346, 5100068309
Net installed power	1,8 kW
Measured sound power level	106 dB(A)
Guaranteed sound power level	108 dB(A)

Conformity assessment procedure

2000/14/EC, Annex VIII

Notified body

TÜV Rheinland LGA Products GmbH, Tillystr. 2, 90431 Nürnberg (DE) (NB 0197)

Directives and standards

We hereby declare that this product complies with the relevant provisions and requirements of the following directives and standards:

2006/42/EC • 2000/14/EC • 2014/30/EU • EN 500-1:2006 + A1:2009 • EN 500-4:2011
EN ISO 13766-1:2018

Person responsible for technical documents

Wacker Neuson Produktion GmbH & Co. KG, Wackerstraße 6, 85084 Reichertshofen (DE)

Reichertshofen (DE), 13.06.2022

Helmut Bauer
Managing Director



**WACKER
NEUSON**

all it takes!

EU Declaration of Conformity

Manufacturer

Wacker Neuson Produktion GmbH & Co. KG, Wackerstraße 6, 85084 Reichertshofen (DE)

This declaration of conformity is issued under the sole responsibility of the manufacturer.

Product	BS50-2
Product type	Vibratory rammer
Function of product	Soil compaction
Material number	5100030592, 5100030597
Net installed power	1,8 kW
Measured sound power level	104 dB(A)
Guaranteed sound power level	108 dB(A)

Conformity assessment procedure

2000/14/EC, Annex VIII

Notified body

TÜV Rheinland LGA Products GmbH, Tillystr. 2, 90431 Nürnberg (DE) (NB 0197)

Directives and standards

We hereby declare that this product complies with the relevant provisions and requirements of the following directives and standards:

2006/42/EC • 2000/14/EC • 2014/30/EU • EN 500-1:2006 + A1:2009 • EN 500-4:2011

EN ISO 13766-1:2018

Person responsible for technical documents

Wacker Neuson Produktion GmbH & Co. KG, Wackerstraße 6, 85084 Reichertshofen (DE)

Reichertshofen (DE), 13.06.2022

Helmut Bauer

Managing Director

Original Declaration of Conformity

BS50-2_CE_en



**WACKER
NEUSON**
all it takes!

EU Declaration of Conformity

Manufacturer

Wacker Neuson Produktion GmbH & Co. KG, Wackerstraße 6, 85084 Reichertshofen (DE)
This declaration of conformity is issued under the sole responsibility of the manufacturer.

Product	BS60-2
Product type	Vibratory rammer
Function of product	Soil compaction
Material number	5100030600, 5100030602, 5100030603, 5100030604, 5100037561, 5100039660, 5100051580
Net installed power	1,9 kW
Measured sound power level	105 dB(A)
Guaranteed sound power level	108 dB(A)

Conformity assessment procedure

2000/14/EC, Annex VIII

Notified body

TÜV Rheinland LGA Products GmbH, Tillystr. 2, 90431 Nürnberg (DE) (NB 0197)

Directives and standards

We hereby declare that this product complies with the relevant provisions and requirements of the following directives and standards:

2006/42/EC • 2000/14/EC • 2014/30/EU • EN 500-1:2006 + A1:2009 • EN 500-4:2011
EN ISO 13766-1:2018

Person responsible for technical documents

Wacker Neuson Produktion GmbH & Co. KG, Wackerstraße 6, 85084 Reichertshofen (DE)

Reichertshofen (DE), 13.06.2022

Helmut Bauer
Managing Director



**WACKER
NEUSON**

all it takes!

EU Declaration of Conformity

Manufacturer

Wacker Neuson Produktion GmbH & Co. KG, Wackerstraße 6, 85084 Reichertshofen (DE)

This declaration of conformity is issued under the sole responsibility of the manufacturer.

Product	BS70-2
Product type	Vibratory rammer
Function of product	Soil compaction
Material number	5100030607, 5100030608, 5100030609
Net installed power	2,0 kW
Measured sound power level	105 dB(A)
Guaranteed sound power level	108 dB(A)

Conformity assessment procedure

2000/14/EC, Annex VIII

Notified body

TÜV Rheinland LGA Products GmbH, Tillystr. 2, 90431 Nürnberg (DE) (NB 0197)

Directives and standards

We hereby declare that this product complies with the relevant provisions and requirements of the following directives and standards:

2006/42/EC • 2000/14/EC • 2014/30/EU • EN 500-1:2006 + A1:2009 • EN 500-4:2011

EN ISO 13766-1:2018

Person responsible for technical documents

Wacker Neuson Produktion GmbH & Co. KG, Wackerstraße 6, 85084 Reichertshofen (DE)

Reichertshofen (DE), 13.06.2022

Helmut Bauer

Managing Director

Original Declaration of Conformity

BS70-2_CE_en

2 Foreword

2.1 Introduction

This operator's manual contains important information and procedures for the safe, proper and economical operation of this machine. Careful reading, understanding and observing it helps to avoid hazards, reduce repair costs and downtimes and thus increase the availability and service life of the machine.

This operator's manual is not a manual for extensive maintenance or repair work. Such work must be carried out by the service partner or by technically trained personnel. The machine must be operated and maintained in accordance with the instructions in this operator's manual. Improper operation or maintenance can cause hazards.

Defective machine parts must be replaced immediately!

The manufacturer is always available to answer questions on operation or maintenance.

2.2 Storage Location of the Operator's Manual

This operator's manual must be kept in the immediate vicinity of the machine and accessible to personnel at all times.

If a second copy of this operator's manual is lost or required, the following options are available for obtaining a replacement:

- On the Internet at <http://www.wackerneuson.com>.
- Contact the manufacturer.

2.2.1 Understanding These Instructions

This section helps to understand the operator's manual and the illustrations used therein.

Target group



People working with this machine must be regularly trained with regard to the dangers and risks occurring when using this machine.

This operator's manual is aimed at:

- Operating personnel:
 - These people have been instructed in working with the machine and about possible dangers and risks arising due to improper behavior.
- Technically trained personnel:
 - These people have a professional training as well as additional knowledge and experience. They are capable of assessing the tasks assigned to them and recognizing any possible risks and dangers.

Explanation of symbols

Symbol	Explanation
1., 2., 3...	Indicates an activity. The sequence of the steps must be observed.

Symbol	Explanation
⇒	Indicates a result or an intermediate result of an action.
✓	Indicates prerequisites that must be established for the activity.
•	Indicates a list, e.g. if several components are named one after the other.
-	Indicates a sub-list, e.g. if components consist of further components
	Identifies a position, usually a component or control element, in a graphic. The numbering may be sequential or in Roman numerals.
1; A	Indicates the naming of components in explanatory texts. It is identical with the adjacent positions in the illustrations.
 	Indicates a direction of movement or different positions for switches.
▶	Indicates the avoidance of hazards in warning notices.
[▶52]	Indicates a cross-reference in tables. Here e.g. reference to page 52

2.2.1.1 Explanation of symbols

The symbols used in the operator's manual are explained below. The symbols are used exclusively in warning or environmental instructions or information. Warnings must always be observed to protect the operator and third parties from personal injury and damage to property.



Symbol for warning notices

This symbol marks general warnings. It is used to alert you of possible hazards, e.g. risks of injury or accidents.



Symbol for indications of technical damage

This symbol is a warning symbol that indicates a danger of technical damage. It is used to indicate situations where damage to the machine or third-party property may occur.



Symbol for environmental information

This symbol indicates environmental information. It is used to warn of possible environmental hazards.



Symbol for information

This symbol indicates information. This information can include tips on operation, for example. It helps to better understand and use the machine.

2.3 Accident Prevention Regulations

In addition to the notes and safety instructions in this operator's manual, the local accident prevention regulations and the national industrial safety regulations apply.

2.4 Contact person

Depending on the country, the contact person is a service partner, a subsidiary or a dealer.

- On the Internet at <http://www.wackerneuson.com>.

2.5 Limitation of liability

In the event of the following infringements, the manufacturer disclaims any liability for personal injury and damage to property:

- Actions contrary to this operator's manual.
- Non-designated use
- Deployment of untrained personnel.
- Use non-approved spare parts and accessories.
- Improper handling.
- Structural changes of any kind.
- Non-observance of the General Terms and Conditions (GTC).

2.6 Use of the operator's manual

This operator's manual:

- must be regarded as an integral part of the machine and must be kept in a safe place throughout its service life.
- must be passed on to each subsequent owner or operator of this machine.
- applies to various machine types from one product range. For this reason, some illustrations may differ from the appearance of the purchased machine. Variant-dependent components that are not included in the scope of delivery can also be described.

The manufacturer reserves the right to change the information in this operator's manual without notice.

It must be ensured that any changes or additions made by the manufacturer are immediately incorporated into this operator's manual.

Group - Type	Material number (Mat. no.)
BS50-2 6"	5100030592
BS50-2plus 6"	5100030597
BS50-2 10"	5100058346
BS50-2 11"	5100068309
BS50-2 11"	5100030591
BS50-2plus 11"	5100030596
BS60-2 11"	5100030600
BS60-2 11"	5100051580
BS60-2 11"	5100037561
BS60-2plus 11"	5100030604
BS70-2 11"	5100030607
BS70-2plus 11"	5100030609

3 Usage

3.1 Designated use

Designated use also includes observing all notes and safety instructions in this operator's manual and observing the prescribed care and maintenance instructions.

Any other use or use that goes beyond this is considered improper use. The manufacturer shall not be liable or liable for any damage resulting therefrom. The risk is borne solely by the operator.

The machine is used for:

- Compaction of cohesive, mixed and granular soils.
- Soil compaction in trenches.
- Backfilling of structures.
- Use in civil engineering, gardening and landscaping.
- Asphalt compaction.

3.2 Unintended use

The manufacturer is not liable for personal injury or damage to property resulting from unintended use. The following activities, among others, are not intended:

- Connecting non-permitted components.
- Operating the machine outside the performance data.
- Compaction of strongly cohesive soils.
- Compaction of frozen soils.
- Compaction of hard, non-compactable soils.
- Compaction of non-load-bearing soils.
- Shaking in cobblestones.

4 Safety

4.1 Safety symbols and signal words

The following symbol identifies safety instructions. It is used for warning against potential personal risk or danger.



DANGER

DANGER identifies a situation causing death or serious injury if it is not avoided.

Consequences in case of non-observance.

- ▶ Avoidance of injury or death.



WARNING

WARNING identifies a situation that can cause death or serious injury if it is not avoided.

Consequences in case of non-observance.

- ▶ Avoidance of injury or death.



CAUTION

CAUTION identifies a situation that can cause injury if it is not avoided.

Consequences in case of non-observance.

- ▶ Avoidance of injury.



NOTICE

INFORMATION identifies a situation that causes damage if it is not observed.

Consequences in case of non-observance.

- ▶ Avoidance of damage to property.

4.2 Principle

The machine has been designed and built in accordance with latest state-of-the-art standards and the recognized safety regulations. Nevertheless, improper use may result in danger to life and limb of the operator, third parties or damage to the machine and other material property.

Read and observe the notes and safety instructions in this operator's manual. Failure to follow these instructions may result in electric shock, fire and/or serious injury, and damage to the machine and/or other objects.

Keep safety instructions and information for the future.

4.3 Structural changes

Structural modifications may not be made without the written consent of the manufacturer. Unauthorized structural changes may result in hazards to the operator and/or third parties as well as damage to the machine.

The manufacturer's liability and warranty are also void in the event of unauthorized structural alterations.

In particular, a structural change shall be deemed to have occurred:

- When opening of the machine and permanent removal of components.
- Installation of spare parts that do not come from the manufacturer or are not equivalent in design and quality to the original parts.
- Attachment of accessories of any kind that do not originate from the manufacturer.

Spare parts or accessories from the manufacturer can be installed or removed safely. Further information is available on the Internet at - <http://www.wackerneuson.com>.

4.4 Responsibility of the operator

The operator is the person who operates this machine himself for commercial or economic purposes or who leaves it to a third party for use/application and bears the legal product responsibility for the protection of personnel or third parties during operation.

The operator must make the operator's manual accessible to the personnel at all times and ensure that the operator has read and understood the operator's manual.

The operator's manual must be kept ready to hand at the machine or at the place of use.

The operator must hand over the operator to any other operator or subsequent owner of the machine.

The country-specific regulations, standards and directives on accident prevention and environmental protection must also be observed. The operator's manual must be supplemented by further instructions for compliance with operational, official, national or generally applicable safety guidelines.

4.5 Obligations of the operator

- Know and implement applicable health and safety regulations.
- In a risk assessment, identify hazards arising from working conditions at the place of use.
- Create operating instructions for the operation of this machine.
- Regularly check whether the operating instructions correspond to the current status of the regulations.
- Clearly regulate and define responsibilities for installation, operation, troubleshooting, maintenance and cleaning.
- Train personnel at regular intervals and inform them about possible dangers.
- Refresh instruction at regular intervals.
- Keep records of the training received and make them available to the competent authority on request.
- Provide personnel with the necessary protective equipment.

4.6 Qualification of staff

This machine may only be put into operation and operated by trained personnel.

In the event of misuse, abuse or operation by untrained personnel, there is a danger to the health of the operators and/or third parties, as well as damage or total failure of the machine.

In addition, the following requirements apply to the operator:

- Physical and mental suitability.
- Minimum age 18 years.
- No influence on reactivity by drugs, alcohol or medication.
- Familiarity with the safety instructions in this operator's manual.
- Familiarity with the intended use of this machine.
- Instructed in the independent operation of the machine.

4.7 General safety instructions

The safety instructions in this chapter contain the "General safety instructions", which must be listed in the operator's manual in accordance with the applicable standards. It may contain instructions which are not relevant for this machine.

4.7.1 Workplace

- Before starting work, familiarize yourself with the working environment, e.g. load-bearing capacity of the floor or obstacles in the environment.
- Secure work area to public transport area.
- Necessary protection of walls and ceilings, e.g. in trenches.
- Keep unauthorized persons and children away when working with this machine. Distraction may result in loss of control of the machine, work must be carried out carefully.
- Always secure the machine against tipping, rolling, slipping and falling. Risk of injury!
- Keep work area tidy. Disorder or unlit work areas can lead to accidents.
- Observe the changing ground conditions, especially on uneven and soft ground or on slopes. Secure the machine against slipping!
- When working near pits, ditches or plateaus, exercise caution! The load-bearing capacity of the ground must safely carry the weight of the machine and the operator.

4.7.2 Personal safety

- Working under the influence of drugs, alcohol or medication can lead to serious injuries.
- Suitable protective equipment must be worn for all work. Personal protective equipment considerably reduces the risk of injury.
- Keep wide or loose clothing, protective gloves, jewellery and long hair away from moving machine parts. Danger of being drawn in!
- Always ensure that you are standing in a stable position, always stand with both feet on the ground.
- During prolonged work with this machine, long-term vibration-related damage cannot be ruled out completely. Vibration load, [see Technical Data on page 47](#).
- Ensure that there are no other persons in the danger zone!

Personal protective equipment



▲ WARNING

Risk of hearing damage if the country-specific noise limit is exceeded!

Working with the machine without hearing protection can lead to hearing damage in the long-term.

- ▶ Wear ear protectors.
- ▶ Work attentively and cautiously when using hearing protection.

4.7.3 Handling and use

- Handle machines with care. Do not operate machines whose components or control elements are defective. Have defective components or control elements replaced immediately. Machines with defective components or control elements entail a high risk of injury!
- Do not lock, manipulate or alter the machine operating elements in an inadmissible manner.
- Secure unused machines against unauthorized putting into operation. The machine may only be operated by authorized personnel.
- Handle machine with care. Have defective parts replaced immediately before this machine is commissioned. Defective machines entail a high risk of injury.
- Use the machine, accessories, tools etc. in accordance with these instructions.
- After operation, store the machine in a locked, clean, frost-protected, and dry location that is inaccessible to other persons and children.

4

4.8 Specific rammer-related safety instructions

4.8.1 External influences



WARNING

Fire and explosion hazard!

The use of machines in potentially explosive environments or near open flames may result in an explosion or a fire.

- ▶ Do not operate the machine in a potentially explosive environment.
- ▶ Do not operate the machine in the vicinity of open flames.
- ▶ Do not operate the machine in oilfield environments - methane gas leaks from the ground.
- ▶ Do not operate the machine in dry, highly flammable vegetation.

4.8.2 Operational safety



⚠ CAUTION

Risk of collapse and spillage!

There is a risk of injury from falling or spilling when working on fracture, pit, dump and embankment edges, on trench edges and heels.

- ▶ Pay attention to side walls and their stability.
- ▶ Ensure stability.

- When operating the machine, make sure that no gas, water or electrical lines or pipes are damaged.
- Exercise the utmost degree of caution near abysses or slopes.
- Never let the machine run unattended.
- Keep work area clear and keep unauthorized persons away.
- Make sure that persons located in the work area maintain a minimum distance of 2 meters from the running machine.

4.8.2.1 Safety distances

Compaction work in the vicinity of buildings can lead to building damage. Therefore, any possible effects and vibrations on surrounding buildings must be checked in advance.

The relevant regulations and codes of practice for measuring, assessing and reducing vibration immissions must be observed, in particular DIN 4150-3.

The manufacturer shall not be liable for any damage to buildings.

4.8.3 Conduct

If this machine is operated for a longer period of time, vibration-induced circulatory disorders may occur in fingers, hands or wrists.

Symptoms:

- Numbness of the mentioned body parts, tingling, pain, stinging and changes in skin color.
- In the case of a personal predisposition to poor blood circulation, the working time can be reduced despite protective gloves and regular breaks from work.
- If these symptoms are detected, consult a doctor immediately.

4.9 Safety features

Safety features protect the operator of this machine from being exposed to the existing hazards. These are barriers (separating protective devices) or other technical measures that serve to avert or reduce hazards.



⚠ WARNING

Hot exhaust!

Contact may cause burns.

- ▶ Only operate the machine if the safety features are correctly fitted.
- ▶ Do not change or remove safety devices.

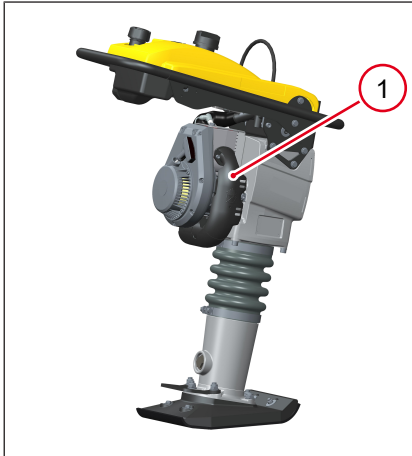

Burn protection 1 protects the operator from contact with hot surface.

4

4.10 Maintenance

- The machine must not be serviced, repaired, adjusted or cleaned when switched on.
- Observe maintenance intervals according to maintenance plan. Have work that is not listed performed by a service partner.
- Replace worn or damaged machine parts immediately. Only use spare parts from the manufacturer.
- Keep the machine clean.
- Replace any missing, damaged or illegible safety labels immediately. Safety and information labels contain important information for the protection of the operator.
- Carry out maintenance work in a clean and dry environment (e.g. workshop).

4.10.1 Service

- Only have the machine repaired or serviced by technically trained personnel.
- Only use original spare parts and accessories. The operational safety of the machine is thus maintained.

4.10.1.1 Threaded fittings

All threaded fittings must comply with the specified specifications and be firmly bolted together. Observe the tightening torques! Screws and nuts must not be damaged, bent or deformed.

Particular attention should be paid to the following:

- Self-locking nuts and micro-encapsulated screws must not be reused after loosening. The fastening effect is lost.
- Threaded fittings with adhesive protection/liquid adhesives (e.g. Loctite) must be cleaned after loosening and provided with new adhesive.



Information

Observe the instructions of the liquid adhesive manufacturer.

4.10.2 Vehicle fluids

- Always wear protective goggles and gloves when handling vehicle fluids. Seek medical advice immediately if, for example, hydraulic oil, fuel, oil or coolant gets into the eyes.
- Avoid direct skin contact with vehicle fluids. Wash skin immediately with soap and water.
- Do not eat or drink while working with vehicle fluids.
- Contaminated vehicle fluid (e.g. with dirt, water) can lead to premature wear or failure of the machine.
- Dispose of discharged or spilled vehicle fuel in accordance with applicable environmental regulations.
- If vehicle fluids leak from the machine, stop operating the machine and have it repaired immediately by a service partner.

4.10.3 Combustion engine



⚠ WARNING

Danger of poisoning!

Inhalation of exhaust fumes can lead to death in a few minutes. Exhaust gases contain carbon monoxide.

- ▶ Do not operate the machine in a closed area, e.g. a tunnel.
- ▶ Unless there is adequate ventilation through exhaust fans or hoses.

- Before starting work, check the engine for leaks and cracks in the fuel line, tank and filler cap.
- Do not start the defective motor. Replace damaged parts immediately.
- The preset engine speed must not be adjusted. This could lead to engine damage.
- Ensure that the exhaust system of the engine is free of flammable materials. Fire hazard!
- Before refueling, switch off the engine and let it cool down.
- Use the correct type of fuel. Observe the prescribed mixing ratios.
- Use clean filling aids for refueling. Do not spill fuel, wipe up spilled fuel immediately.
- Do not start the engine near spilled fuel. Explosion hazard!
- When operating in partially enclosed rooms, sufficient ventilation must be provided. Do not inhale exhaust gas. Danger of poisoning!
- The engine surface and exhaust system can become very hot after only a short time. Risk of burns!
- Do not use jump start sprays. These can cause misfiring and engine damage. Fire hazard!
- Smoking prohibited!

5 Description of the Machine

5.1 Type plates and labels

5.1.1 Type label

A type label is permanently attached to the machine.

Other type labels

Furthermore, the following components of the machine are provided with their own type label:

- the combustion engine

Symbols on the type label

Various symbols and markings for national and international approvals can be shown on or next to the nameplate.

5.1.1.1 Labeling on the machine

Type label data

The type label contains information that uniquely identifies this machine. This information is required for ordering spare parts and for technical queries.

Enter the data on the machine in the following table:

Designation	Your details
Group - Type	
Material number (Mat. no.)	
Machine version (version)	
Machine number (machine no.)	
Year of construction	

5.1.2 Safety and information labels



⚠ WARNING

Injury hazard due to missing or damaged labels and signs!

Safety labels contain important information to protect the operator.

- ▶ Keep all safety, warning and operating instructions on the machine in a clearly legible condition.
- ▶ Replace missing or damaged labels and signs immediately.

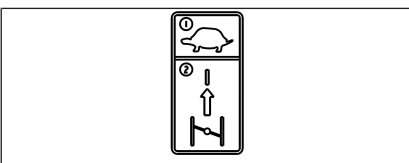
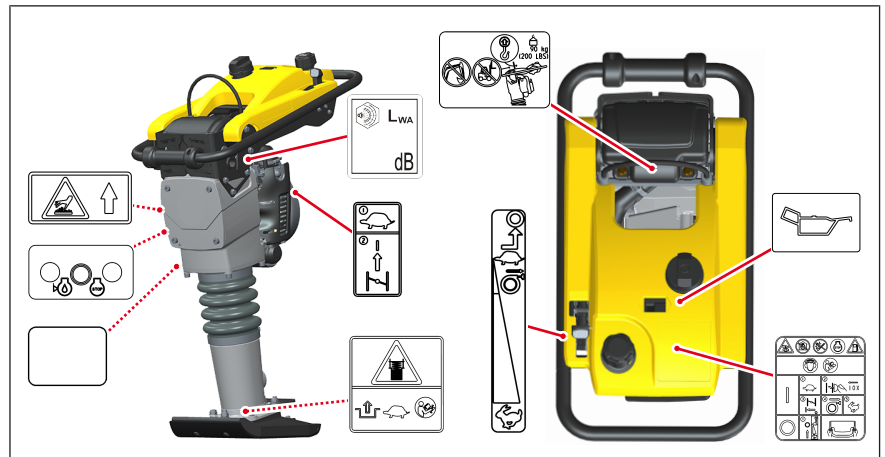

- 1) Set throttle lever to idle.
- 2) Activate choke.

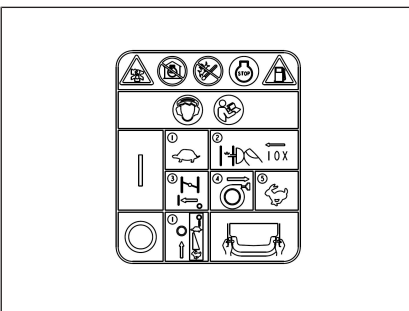

Danger of suffocation!

- Engines emit carbon monoxide.
- Do not operate the machine in closed rooms.
- No sparks, flames or burning objects are permitted near the machine.
- Stop the machine before filling up with fuel.

Note!

- Wear ear protectors.
- Read the operator's manual.
- Start / stop brief instructions.
- For optimal control, performance and minimum hand and arm vibration, hold the guide bracket on the left and right.

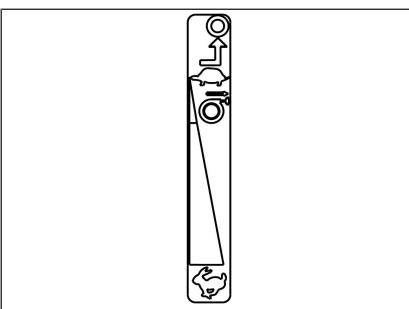

Throttle lever positions

- Turtle = Idle / low engine speed.
- Rabbit = High / fast engine speed.

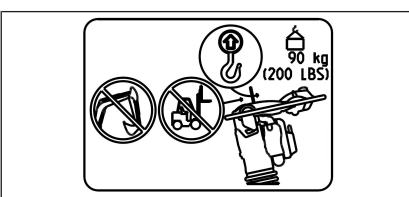

- Only use suitable and tested lifting gear and slings (safety hooks) with sufficient lifting capacity.
- Do not lift the machine with an excavator bucket or forklift truck on the central suspension.

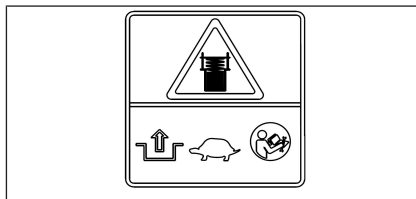

Warning!

Release the cover slowly so that the spring does not pop out.
Read the repair instructions.

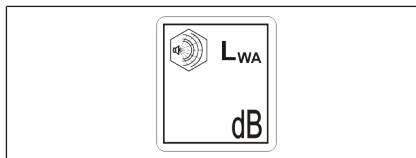

Guaranteed sound power level.

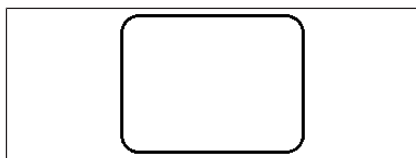

Type label.



Warning of hot surface.

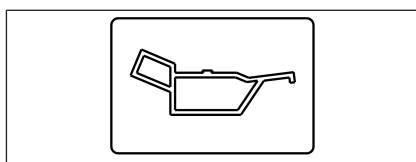

Tank capacity 2-stroke oil.

5.2 Components

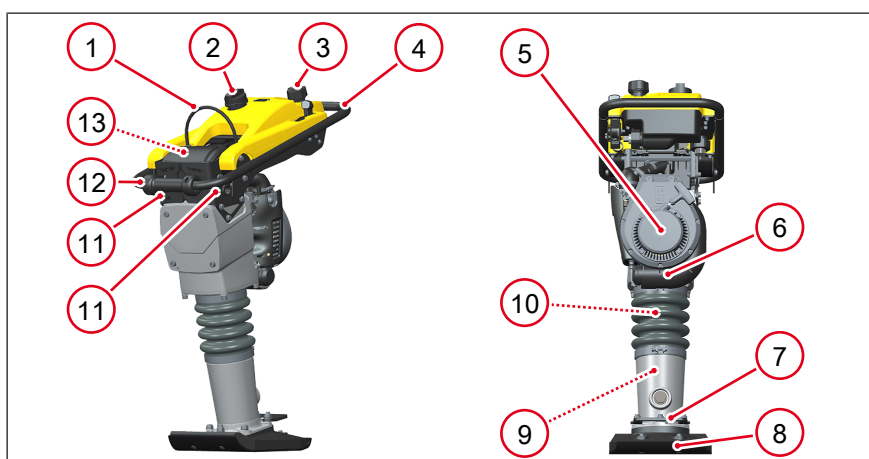

- 1 Central suspension
- 2 Oil tank (optional)
- 3 Fuel tank
- 4 Guide bracket
- 5 Drive motor

- 6 Exhaust
- 7 Handle
- 8 Ramming plate
- 9 Ramming system
- 10 Bellows
- 11 Rubber buffer
- 12 Transport roller
- 13 Air filter system

5.3 Control elements

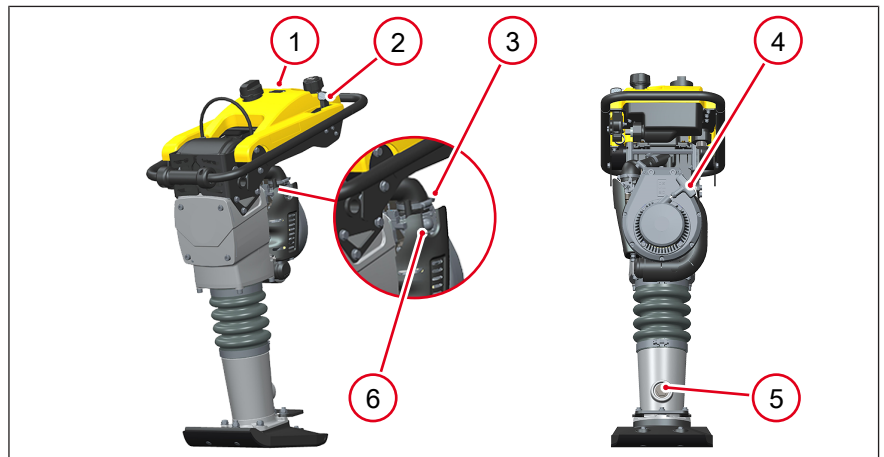

- 1 Operating hour meter / speed display (optional)
- 2 Throttle lever
- 3 Choke lever
- 4 Starting handle
- 5 Sight glass
- 6 Purger

6 Transportation

6.1 Safety instructions for transport



⚠ WARNING

Fire hazard due to fuel!

Leaking fuel can catch fire and cause severe burns.

- ▶ Empty the fuel tank before transport.



Information

Fuel leakage!

During transport, fuel may escape through the pressure relief valve.

- ▶ Drain the fuel system before transport.
- ▶ Observe the dangerous goods regulations of the means of transport and the national safety guidelines.

6.2 Prerequisites and preparations



Information

Fuel leakage!

During transport, fuel may escape through the pressure relief valve.

- ▶ Drain the fuel system before transport.
- ▶ Observe the dangerous goods regulations of the means of transport and the national safety guidelines.

- Switch off the engine and let it cool down.
- Drain fuel, [see Maintenance on page 33](#).
- Lean the machine upright against a solid object and secure against tipping over. Manufacturer recommends placing machine on transport cart, [see Accessories on page 45](#).

6.3 Lifting the machine



⚠ WARNING

Risk of crushing!

Crushing of hands and feet possible.

- ▶ Work cautiously.



NOTICE

Note on the lifting procedure!

- ▶ Designate a competent instructor for a safe lifting procedure.

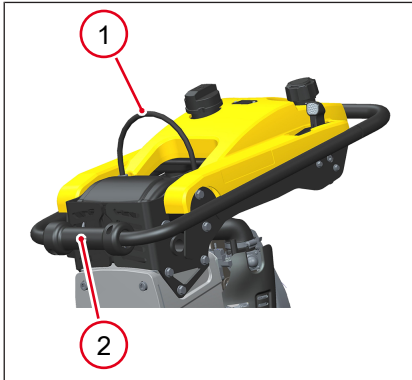

1. Attach suitable sling to central suspension **1**.
2. Load the machine into or onto the transport vehicle.
3. Transfer the machine to the front onto the transport roller **2**.

6.4 Lashing the machine

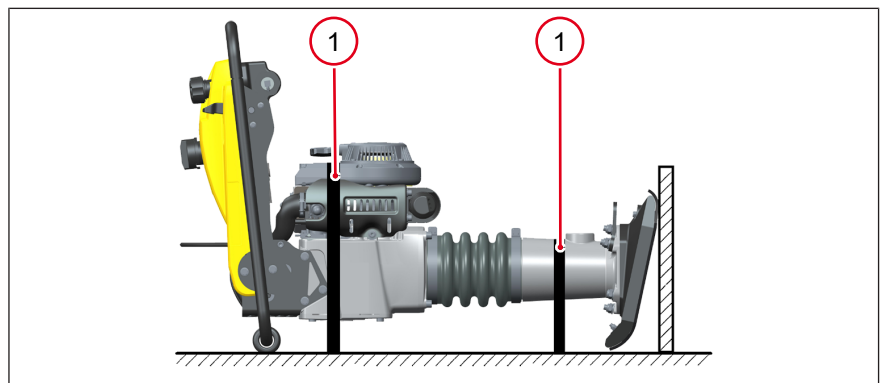

1. Lash the machine to the transport vehicle as shown.
2. Attach the tension belts **1** over the machine and tighten them.
⇒ The machine is secured against unrolling, slipping and tipping over.

7 Commissioning

7.1 Safety instructions for operation



⚠ WARNING

Tipping hazard!

Risk of serious injury from slipping or overturning machine.

- ▶ Ensure sufficient stability.
- ▶ Always secure the machine against tipping over.
- ▶ Park the machine on a level surface with firm ground.



⚠ WARNING

Risk of crushing!

Crushing of hands and feet possible.

- ▶ Work cautiously.



⚠ WARNING

Risk of injury due to uncontrolled machine operation!

- ▶ Always hold the machine with both hands and take a firm stand.
- ▶ Use safety shoes.



⚠ WARNING

Improper handling may result in injury or serious material damage.

- ▶ Please read and follow all safety instructions in this operator's manual.



⚠ WARNING

Risk of hearing damage if the country-specific noise limit is exceeded!

Working with the machine without hearing protection can lead to hearing damage in the long-term.

- ▶ Wear ear protectors.
- ▶ Work attentively and cautiously when using hearing protection.



⚠ CAUTION

Health hazard due to vibrations!

Physical impairments due to vibration.

- ▶ Take regular breaks.



⚠ CAUTION

Risk of injury and material damage due to recoil!

On firm, hard or unyielding floors, injuries and material damage may result from strong rebounds.

- ▶ Avoid hard or unyielding floors.



⚠ CAUTION

Risk of collapse and spillage!

There is a risk of injury from falling or spilling when working on fracture, pit, dump and embankment edges, on trench edges and heels.

- ▶ Pay attention to side walls and their stability.
- ▶ Ensure stability.

7.2 Tests before commissioning



Information

Further information and detailed descriptions, [see Maintenance on page 33](#).

Perform the following checks:

- Check machine and components for damage.
 - Do not put the damaged machine into operation. Damages and defects must be repaired immediately.
- Check the fuel level.
- Check engine oil fill level.
- Check to ensure the screw connections are firmly seated.
- Check control elements for functionality.
- Check the air intake area for dirt.

7.3 Putting into operation



⚠ CAUTION

Hot exhaust!

Contact may cause burns.

- ▶ Only operate the machine if the safety features are correctly fitted.
- ▶ Do not change or remove safety devices.



⚠ CAUTION

Risk of injury when starting!

Improper handling during starting can lead to minor injuries.

- ▶ Do not pull the starting handle until there is sufficient space and no persons in the immediate vicinity.



NOTICE

Engine damage due to improper handling!

Improper handling can lead to engine damage.

- ▶ Do not pull out starting handle as far as it will go.
- ▶ Let the starting handle retract slowly.

8 Operation

8.1 Operating the machine



▲ WARNING

Risk of injury due to uncontrolled machine operation!

- ▶ Always hold the machine with both hands and take a firm stand.
- ▶ Use safety shoes.



- The operator's designated location is behind the machine.
- Guide and steer the machine using the guide bracket.
- Let the machine move forward on its own. Do not use your muscles to push it forward or pull it back.
- For optimal control, performance and minimum hand and arm vibration, hold the guide bracket on the left and right.
- To avoid damage to the machine, do not move the machine when it is running.
- Exercise caution with rough material. To avoid extreme wear and tear to the ramming plate, ensure that it is always parallel to the ground being compacted.

8.1.1 Compacting material



1. Guide the machine with both hands at the guide bracket.
2. Operate the throttle lever until the desired speed is reached.
3. When the material has been compacted, move the throttle lever to position **A**.
⇒ The machine stops.
4. Lift and transfer the machine.

8.2 Select speed

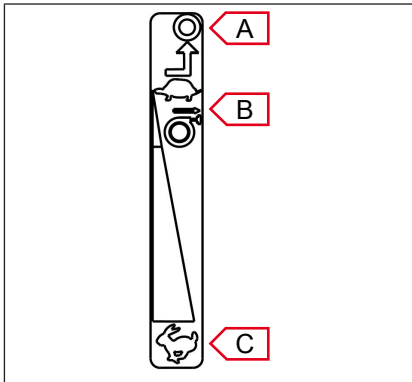

Position A: Stop, machine stands still.

Position B: Idle, slow speed.

Position C: Full speed, fast speed.

8.3 Taking the machine out of operation



⚠ CAUTION

Danger of burns due to hot surfaces!

The machine, engine and exhaust can heat up quickly after a short time; that can lead to severe burns in case of contact with skin.

- ▶ Always allow the machine, engine and exhaust to cool down after use.
- ▶ Use heat-resistant protective gloves if the cooling phase cannot be maintained (e.g. due to an emergency).

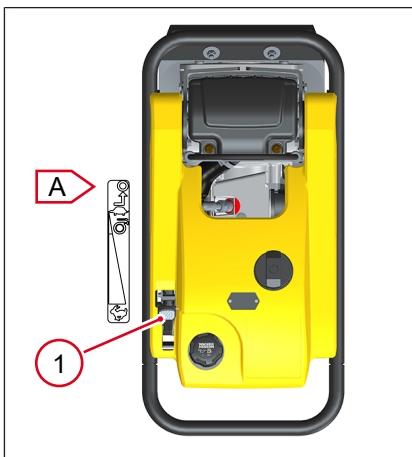

✓ The machine is on a level surface.

1. Move the throttle lever **1** into position **A**.
 - ⇒ Fuel tap closes automatically.
 - ⇒ The machine stops.
2. Allow the machine to come to a complete stop.
3. Let the machine and engine to cool down.
 - ⇒ The machine is out of operation.

9 Maintenance

9.1 Safety instructions for maintenance



⚠ WARNING

Improper handling may result in injury or serious material damage.

- ▶ Please read and follow all safety instructions in this operator's manual.



⚠ WARNING

Hazard of poisoning from exhaust fumes!

Exhaust fumes contain poisonous carbon monoxide, which can lead to unconsciousness or to death.

- ▶ Only perform maintenance work with the engine switched off and the machine decommissioned.



⚠ WARNING

Fire and explosion hazard due to fuel and fuel vapors!

Fuel and fuel vapors can ignite or catch fire and cause serious burns.

- ▶ Do not smoke.
- ▶ Do not refuel near open fire.
- ▶ Switch off the engine and allow it to cool before refueling.



⚠ WARNING

Risk of injury due to missing or non-functioning safety devices!

- ▶ Only operate the machine if the safety devices are correctly installed and functioning.
- ▶ Do not change or remove safety devices.



⚠ CAUTION

Health risk from fuel, lubricants and coolants!

- ▶ Do not inhale vapors.
- ▶ Avoid skin and eye contact.



NOTICE

Damage by penetrating water!

Penetrating water can damage electrical operating elements or machine components.

Penetrating moisture can lead to total failure.

- ▶ Do not clean the machine with high pressure or steam cleaners!
- ▶ Use a cloth to remove water that has entered (e.g. due to rain) the housing and then let the machine dry.
- ▶ Only use dry and clean cloths.



NOTICE

Engine damage from operating the engine without an air filter!

If the engine is operated without an air filter, there is a risk of rapid engine wear.

- ▶ Do not operate the engine without an air filter or air filter cover.



NOTICE

Premature tool failure!

Cooling the tool or tool holder with water can cause premature failure.

- ▶ Do not cool tools and tool holders with water.



Environment

Soil contamination due to oil leaking or overflowing.

- ▶ Line work surface with impermeable foil.
- ▶ Use collecting container for used oil.
- ▶ Dispose of used oil in an environmentally friendly manner in accordance with statutory regulations.

9.2 Maintenance plan

Activity	Daily	Weekly 25 h	Once a month 100 h	2 Monthly 200 h	3 Monthly 300 h	Once a year
Clean the machine.	•					
Visual check for completeness.						
Visual check for damage.						
Clean air filter, replace if necessary.	•					
Check oil level; fill if necessary: <ul style="list-style-type: none"> • Ramming system 	•					

Activity	Daily	Weekly 25 h	Once a month 100 h	2 Monthly 200 h	3 Monthly 300 h	Once a year
Check fuel lines and connections for cracks and leaks, replace if necessary.	•					
Check screw connections of rammer foot plate, retighten if necessary.		•				
Clean engine cooling fins.		•				
Clean spark plug and check gap.		•				
Oil change: • Ramming system				• ¹		
Relubrication interval: • Ramming system				•		
Check central suspension for wear, damage or misuse.					•	
Replace spark plug.						•
Clean fuel filter, have it changed if necessary.*						•
¹ Change oil after first 50 hrs.						
* Have this work carried out by a service partner.						

9.3 Maintenance work

9.3.1 Carrying out preparations

1. Place the machine on a level surface.
2. Decommissioning the machine.
3. Let the machine cool down.

9.3.2 Cleaning the machine

1. Clean machine and components after each use.
2. The manufacturer recommends cleaning with compressed air.
3. Wipe the housing with a damp and clean cloth.
4. After cleaning, check cables and wires for damage.
5. Check screws and bolts to see if they are loose.
6. Remedy any deficiencies noted immediately.

9.3.3 Add fuel



⚠ WARNING

Fire and explosion hazard due to fuel and fuel vapors!

Fuel and fuel vapors can ignite or catch fire and cause serious burns.

- ▶ Do not smoke.
- ▶ Do not refuel near open fire.
- ▶ Switch off the engine and allow it to cool before refueling.

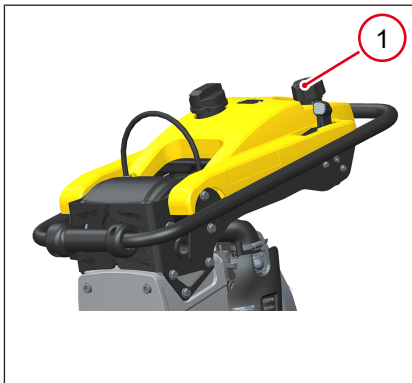

✓ The machine is out of operation.

1. Remove dirt.
2. Open filler cap **1** slowly.
 - ⇒ Any excess pressure can thus slowly escape.
3. Refill fuel to maximum lower edge of the fill opening.
 - ⇒ Fuel specification, [see Technical Data on page 47](#)
 - ⇒ Fuel mixing table, [see Technical Data on page 47](#)
4. Close filler cap tightly.

9.3.4 Emptying the fuel system

1. Remove dirt.
2. Opening the filler cap.
3. Pump fuel into a suitable container or tank, e.g. with a suction lift pump.
4. Close filler cap tightly.
5. Start the engine and let it run at idle until the fuel in the carburetor is used up and the engine stops.

9.3.5 Cleaning and replacing the air filter



NOTICE

Possible engine damage!

- ▶ Do not allow dirt to enter the engine intake duct when cleaning.

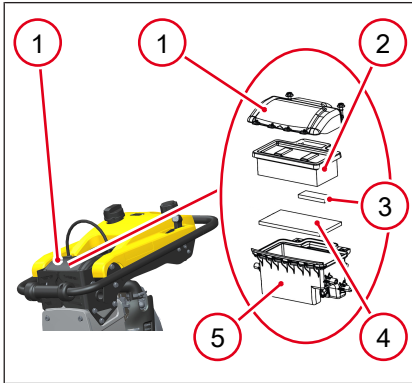

1. Remove air filter lid **1**.
2. Remove air filter element **2** and separate filter elements.
⇒ Pre-filter **3** and foam filter insert **4**.
3. Check both air filter elements for cracks and holes, replace if damaged.

Cleaning the air filter insert

1. Knock out air filter insert on a hard surface.
2. Blow with compressed air from the inside through the filter insert.

Cleaning the foam filter insert

1. Wash out foam filter insert in soapy water.
2. Rinse thoroughly with warm water.
3. Rinse with clean water.
4. Leave to dry.

Cleaning the filter housing

1. Wipe out filter housing **4** with a cloth.
2. Do not use compressed air!
3. Clean the dirt discharge slot of the pre-filter.
4. Insert both filter elements into the filter housing.
5. Screw on air filter cover.

9.3.6 Checking and refilling the oil level in the tamping system



NOTICE

Damage to machine due to incorrect oil level!

A too high oil level can result in a hydraulic lock in the ramming system. This can lead to faulty operation and damage to the ramming system.

- ▶ Do not overfill the ramming system with oil.

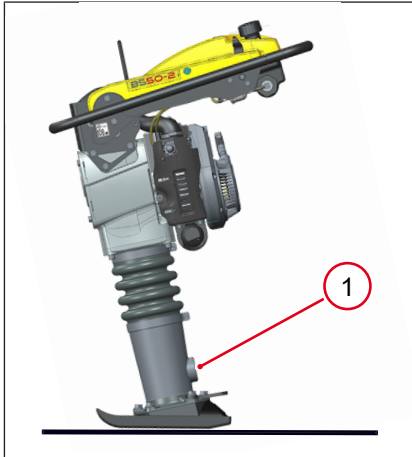

✓ Machine is in an upright and stable position for at least 15 minutes.

1. Remove dirt in the area of the sight glass 1.
2. Check the oil level through the sight glass.
⇒ The oil level must be between $\frac{1}{2}$ and $\frac{3}{4}$.
3. If necessary, top up oil, [see Technische Daten on page 47](#).

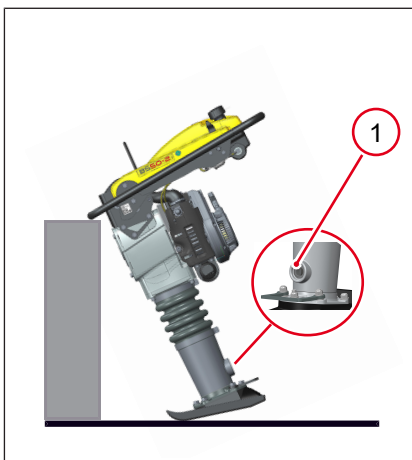

Refilling the oil level in the ramming system

1. Tilt the machine forward to access the sight glass 1.
2. Secure the machine in this position.
3. Unscrew the sight glass.
4. Clean the thread on the sight glass.

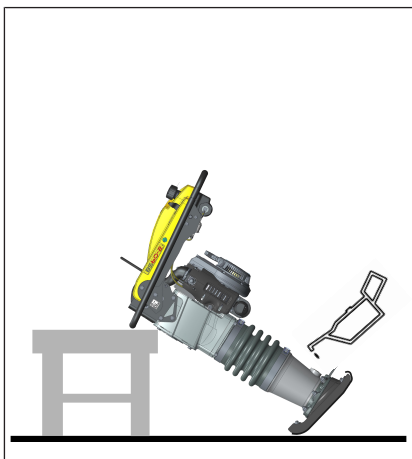

5. Pour oil into the housing through the opening in the sight glass.
6. Tighten the sight glass.
7. Place the machine in upright position to check the oil level.
8. If necessary, top up oil until the sight glass $\frac{1}{2}$ to $\frac{3}{4}$ is filled.
9. Tighten the sight glass again. Tightening torque 9 Nm.
10. Wipe the area of the sight glass with a clean cloth.

9.3.7 Changing oil in the ramming system



Environment

Soil contamination due to oil leaking or overflowing.

- ▶ Line work surface with impermeable foil.
- ▶ Use collecting container for used oil.
- ▶ Dispose of used oil in an environmentally friendly manner in accordance with statutory regulations.

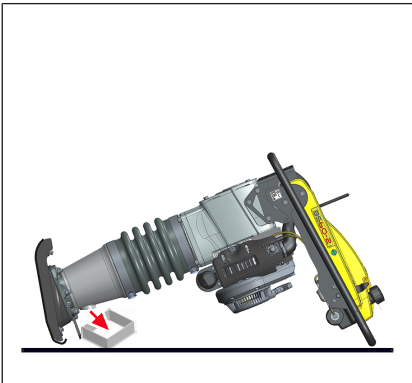

1. Remove dirt.
2. Provide a suitable container for draining the used oil.
3. Unscrew the sight glass.
4. Clean the thread on the sight glass.
5. Tilt the machine backwards until it is resting on the guide bracket.
6. Allow the used oil to drain completely.

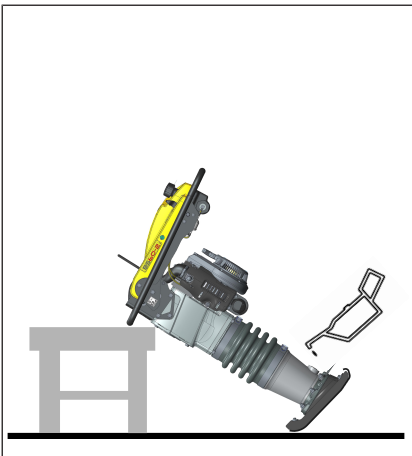

7. Tilt the machine forward and secure it in this position.
8. Fill oil into the housing through the opening in the sight glass, [see Technical data on page 47](#).
9. Tighten the sight glass.



10. Place the machine in upright position to check the oil level.
11. If necessary, top up oil until the sight glass $\frac{1}{2}$ to $\frac{3}{4}$ is filled.
12. Tighten the sight glass again. Tightening torque 9 Nm.
13. Wipe the area of the sight glass with a clean cloth.

9.3.8 Check screw connections of the ramming plate

1. Check all screw connections for tightness at regular intervals.
2. Tighten loose screw connections.

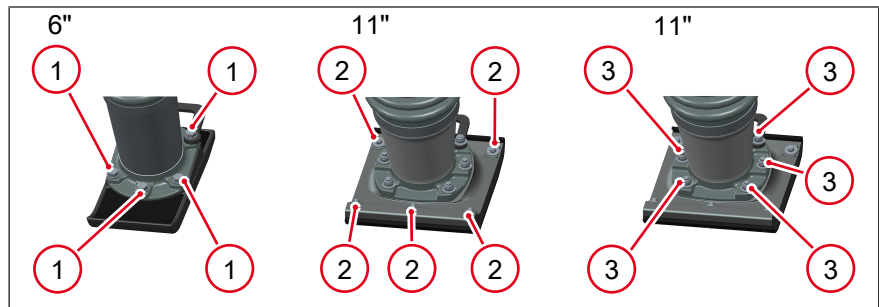

Tightening torque in Nm (ft-lbs.)	
1	86 (63)
2	19 (14)
3	79 (58)

9.3.9 Cleaning the cooling fins

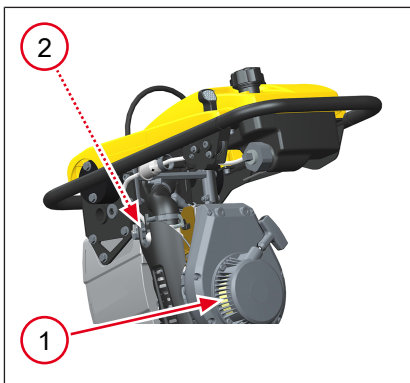

- Clean cooling fins on reversing starter **1** and on engine **2** with compressed air to remove dirt and residues.

9.3.10 Checking and changing the spark plug



⚠ CAUTION

Risk of burns!

Contact with hot spark plug can cause burns.

- ▶ Only unscrew the spark plug when the engine has cooled down.
- ▶ Use protective gloves.



NOTICE

- ▶ Do not pull the spark plug connector from the spark plug by the ignition cable.



NOTICE

Danger of engine damage!

An incorrect spark plug can cause engine damage, see [Technical Data on page 47](#).

- ▶ Correct electrode spacing.
- ▶ Free of deposits.



NOTICE

Hazard of engine damage!

Too loose or too tightly screwed in spark plug can lead to engine damage.

- ▶ Tighten the spark plugs to the prescribed tightening torque.

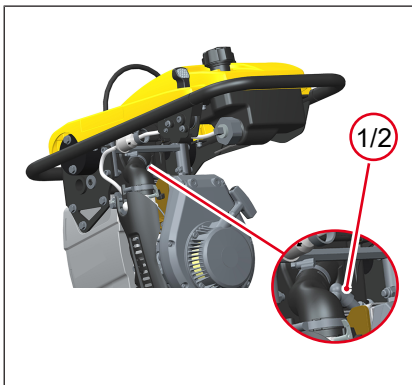

Remove spark plug

- ✓ The engine is switched off.
 - ✓ The machine has cooled down.
1. Pull out spark plug connector 1.
 2. Remove dirt in spark plug area 2.
 3. Unscrew spark plug and check.

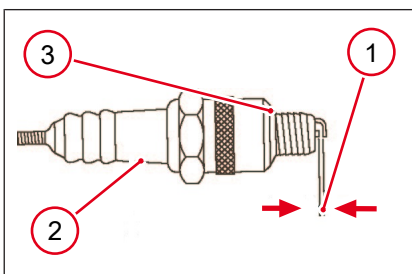

Checking and cleaning the spark plug

1. Check the isolator 2.
2. Replace if damaged or heavily soiled.
3. Clean the electrode with a wire brush.
4. Measure electrode distance 1. see [Technical Data on page 47](#)
5. Correct the electrode spacing by carefully bending it.
6. Check spark plug sealing ring 3.
7. Replace if damaged.

Install spark plug.

1. Tighten spark plug, tightening torque 22 Nm.
2. Plug the spark plug connector onto the spark plug.

9.3.11 Cleaning and replacing the fuel filter



NOTICE

Connect fuel line correctly!

- ▶ To ensure a safe connection, cut off approx. 10 mm (3/8") from the end of the fuel line and connect to the fuel filter.

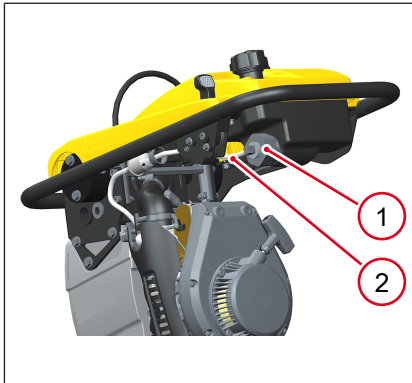

1. Disconnect fuel line **2** and remove from fuel filter.
2. Unscrew and remove fuel filter **1**.
3. Wipe visible debris and dirt particles from outside of fuel filter screen with a clean, dry, lint-free cloth.
4. Check fuel filter screen for cracks, damage and dirt particles, replace if damaged or soiled.
5. Reinstall the fuel filter.
6. Before restarting the machine, check fuel system for leaks.

10 Troubleshooting

10.1 Troubleshooting

Fault	Possible cause	Remedy
Engine does not start.	Fuel cock is closed.	Set throttle lever to idle.
	Fuel tank is empty.	Refill with fuel.
	Fuel filter is soiled.	Change filter.
	Soiled air filter.	Clean filter, replace if necessary.
	Choke lever is deactivated.	Set throttle lever to idle and activate choke.
	Purger not pressed.	Press purger repeatedly.
	Spark plug is defective.	Replace spark plug.
	Spark plug soiled or wet.	Clean spark plug, replace if necessary.
	The electrode gap of the spark plug is set incorrectly.	Adjust the electrode gap.
Engine runs, but machine does not ram.	Centrifugal clutch is defective.	Replace the centrifugal clutch.*
Idling speed too high or too low.	Idling speed adjusting screw incorrectly positioned.	Correct screw position.
Engine power too low.	The air filter is soiled.	Clean filter, replace if necessary.
	Fuel filter is soiled.	Change filter.
Machines with oil injection		
Engine starts and stops after approx. 30 seconds.	Not enough oil in oil tank.	Refill with oil.
	Cable connection on engine loose or slack.	Check connection and correct if necessary.
	Oil sensor in oil tank defective.	Replace oil sensor.*
* Have this work carried out by a service partner.		

11 Shutdown

11.1 Temporary decommissioning



Information

Further information and detailed descriptions, [see Maintenance on page 33](#).

Storage requirements

- Store dust-free and dry.
- Do not store outdoors.
- Protect from direct sunlight.
- Observe storage temperature, [see Technical Data on page 47](#).
- Store in a locked place that is not accessible to children.

If the machine is stationary for more than 1 month, perform the following measures:

Entire machine	<ul style="list-style-type: none"> • Clean thoroughly. • If necessary, rectify all defects. • Check for leaks, rectify any defects if necessary.
Fuel tank	Drain fuel completely.
Engine	<ul style="list-style-type: none"> • Check engine oil level, fill engine oil if necessary. • Check and clean air filter. • Clean fuel filter.

If the machine is shut down for more than 6 months, contact a service partner.

11.2 Final shutdown

If the machine is no longer in use and is shut down for good, all operating fluids must be drained.

Have the machine professionally dismantled and disposed of by a state-approved recycling company.

Professional disposal of this machine avoids negative effects on human health and the environment, helps with the targeted treatment of pollutants and makes it possible to recycle valuable raw materials.

12 Accessories

12.1 Accessories



⚠ CAUTION

Risk of injury and possible machine damage!

Use of non-original spare parts or accessories can lead to injuries or machine damage.

- ▶ Only use original spare parts and accessories.
- ▶ In case of disregard, no liability will be accepted.



⚠ CAUTION

Stability of the machine with wheel set!

Tipping over or rolling away of the machine can lead to injuries or material damage.

- ▶ Park the machine safely.
- ▶ Secure the wheel set against rolling away or fold it up.



Lockable oil tank cap

Lockable oil tank cap prevents misfueling.



Ramming plate

Ramming plates are available in different widths. This allows the working width of the machine to be increased or decreased.



Wheel set

For easier transport on the construction site.



Transport trolley

For easier transport on the construction site.

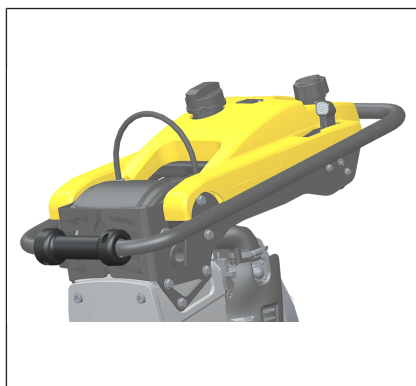

Transport roller

For easier transport on the construction site.

12.2 Transport roller installation

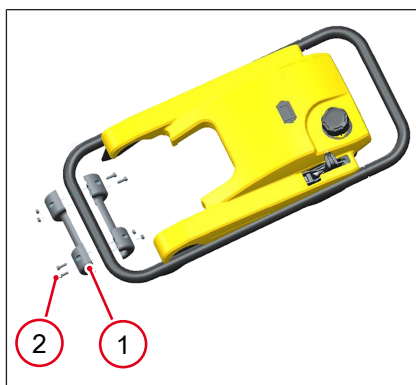

- ✓ Machine is switched off.
- 1. Place the machine horizontally on a flat surface with sufficient load-bearing capacity.
- 2. Secure machine against overturning.
- 3. Align half shells **1** in the middle.
- 4. Attach the half shells with four screws **2** to the guide bracket.
- 5. Tightening torque 1.5 Nm.

13 Technical Data

13.1 General instructions



Information

For system technical reasons, empty columns can be displayed in the technical data, and numbers and letters that written in superscript or subscript may be displayed incorrectly, e.g:

- ▶ Sound power level L_{WA} instead of L_{WA}
- ▶ Sound pressure level L_{pA} instead of L_{pA}
- ▶ Vibration total value a_{hv} instead of a_{hv}
- ▶ Carbon dioxide CO₂ instead of CO_2
- ▶ Unit m/s² instead of m/s^2

13.2 Noise and vibration data

The noise and vibration data listed have been determined in accordance with the following guidelines for the typical machine operating conditions / special test conditions and using harmonized standards:

- Machinery Directive 2006/42/EC
- Noise Emission Directive 2000/14/EC

During operational use, values may differ depending on the prevailing operating conditions.

Sound pressure level at operator station

- L_{pA} was determined according to EN ISO 11201 and EN 500-4.

Guaranteed sound power level

- L_{WA} was determined according to EN ISO 3744 and EN 500-4.

Weighted vibration total value hand-arm vibration

- a_{hv} was determined according to EN ISO 20643 and EN 500-4.

13.3 BS

Type	BS50-2 10"	BS50-2 11"
Material number machine	5100058346	5100068309
Material number engine	5100008899	5100008899
Number of strokes [1/min]	687	687
Impact force [kN]	16	16
Forward travel [m/min]	9,5	9,5
Length [mm]	673	673
Width [mm]	343	343
Height [mm]	940	940
Length (Ramming shoe) [mm]	340	340

Type	BS50-2 10"	BS50-2 11"
Material number machine	5100058346	5100068309
Width (Ramming shoe) [mm]	250	280
Operating weight [kg]	61,6	59
Rated output [kW]	1,8	1,8
Rated speed [1/min]	4400	4400
Standard	ISO 3046-1	ISO 3046-1
Engine type	WM80	WM80
Oil specifications (Ramming system)	SAE 10W-40	SAE 10W-40
Oil volume (Ramming system) [l]	0,7	0,7
Operating temperature range [°C]	-10 – +40	-10 – +40
Storage temperature range [°C]	-30 – +50	-30 – +50
Sound pressure level LpA [dB(A)]	93	93
Sound power level LWA measured [dB(A)]	106	106
Sound power level LWA guaranteed [dB(A)]	108	108
Vibration total value ahv [m/s ²]	11,1	11,1
Measurement uncertainty of the total vibration value ahv [m/s ²]	1,7	1,7

* The actual operating speed depends on numerous operating parameters and may differ from the rated speed.

Type	BS50-2 11"	BS50-2 6"
Material number machine	5100030591	5100030592
Material number engine	5100008899	5100008899
Number of strokes [1/min]	687	687
Impact force [kN]	16	16
Forward travel [m/min]	9,5	7,9
Length [mm]	673	673
Width [mm]	343	343
Height [mm]	940	940
Length (Ramming shoe) [mm]	340	340
Width (Ramming shoe) [mm]	280	165
Operating weight [kg]	59	56
Rated output [kW]	1,8	1,8
Rated speed [1/min]	4400	4400
Standard	ISO 3046-1	ISO 3046-1
Engine type	WM80	WM80
Oil specifications (Ramming system)	SAE 10W-40	SAE 10W-40
Oil volume (Ramming system) [l]	0,7	0,7
Operating temperature range [°C]	-10 – +40	-10 – +40
Storage temperature range [°C]	-30 – +50	-30 – +50
Sound pressure level LpA [dB(A)]	93	92
Sound power level LWA measured [dB(A)]	106	104
Sound power level LWA guaranteed [dB(A)]	108	108
Vibration total value ahv [m/s ²]	11,1	6,5

Type	BS50-2 11"	BS50-2 6"
Material number machine	5100030591	5100030592
Measurement uncertainty of the total vibration value ahv [m/s ²]	1,7	0,6

* The actual operating speed depends on numerous operating parameters and may differ from the rated speed.

Type	BS50-2plus 11"	BS50-2plus 6" (24mm)
Material number machine	5100030596	5100030597
Material number engine	5100009016	5100009016
Number of strokes [1/min]	687	687
Impact force [kN]	16	16
Forward travel [m/min]	9,5	7,9
Length [mm]	673	673
Width [mm]	343	343
Height [mm]	940	940
Length (Ramming shoe) [mm]	340	340
Width (Ramming shoe) [mm]	280	165
Operating weight [kg]	59	56
Rated output [kW]	1,8	1,8
Rated speed [1/min]	4400	4400
Standard	ISO 3046-1	ISO 3046-1
Engine type	WM80	WM80
Oil specifications (Ramming system)	SAE 10W-40	SAE 10W-40
Oil volume (Ramming system) [l]	0,7	0,7
Operating temperature range [°C]	-10 – +40	-10 – +40
Storage temperature range [°C]	-30 – +50	-30 – +50
Sound pressure level LpA [dB(A)]	93	92
Sound power level LWa measured [dB(A)]	106	104
Sound power level LWa guaranteed [dB(A)]	108	108
Vibration total value ahv [m/s ²]	8,9	6,5
Measurement uncertainty of the total vibration value ahv [m/s ²]	1,3	0,6

* The actual operating speed depends on numerous operating parameters and may differ from the rated speed.

Type	BS60-2 11"	BS60-2 11"
Material number machine	5100037561	5100030600
Material number engine	5100008899	5100008899
Number of strokes [1/min]	687	687
Impact force [kN]	18	18
Forward travel [m/min]	9,8	9,8
Length [mm]	673	673
Width [mm]	343	343
Height [mm]	965	965
Length (Ramming shoe) [mm]	340	340
Width (Ramming shoe) [mm]	280	280

Type	BS60-2 11"	BS60-2 11"
Material number machine	5100037561	5100030600
Operating weight [kg]	66	66
Rated output [kW]	1,9	1,9
Rated speed [1/min]	4400	4400
Standard	ISO 3046-1	ISO 3046-1
Engine type	WM80	WM80
Oil specifications (Ramming system)	SAE 10W-40	SAE 10W-40
Oil volume (Ramming system) [l]	0,9	0,9
Operating temperature range [°C]	-10 – +40	-10 – +40
Storage temperature range [°C]	-30 – +50	-30 – +50
Sound pressure level LpA [dB(A)]	94	94
Sound power level LWA measured [dB(A)]	105	105
Sound power level LWA guaranteed [dB(A)]	108	108
Vibration total value ahv [m/s ²]	9,7	9,7
Measurement uncertainty of the total vibration value ahv [m/s ²]	1,7	1,7

* The actual operating speed depends on numerous operating parameters and may differ from the rated speed.

Type	BS60-2 11"	BS60-2plus 11"
Material number machine	5100051580	5100030604
Material number engine	5100008899	5100009016
Number of strokes [1/min]	687	687
Impact force [kN]	18	18
Forward travel [m/min]	9,8	9,8
Length [mm]	673	673
Width [mm]	343	343
Height [mm]	965	965
Length (Ramming shoe) [mm]	340	340
Width (Ramming shoe) [mm]	280	280
Operating weight [kg]	66	66
Rated output [kW]	1,9	1,9
Rated speed [1/min]	4400	4400
Standard	ISO 3046-1	ISO 3046-1
Engine type	WM80	WM80
Oil specifications (Ramming system)	SAE 10W-40	SAE 10W-40
Oil volume (Ramming system) [l]	0,9	0,9
Operating temperature range [°C]	-10 – +40	-10 – +40
Storage temperature range [°C]	-30 – +50	-30 – +50
Sound pressure level LpA [dB(A)]	94	94
Sound power level LWA measured [dB(A)]	105	105
Sound power level LWA guaranteed [dB(A)]	108	108
Vibration total value ahv [m/s ²]	9,7	8,7
Measurement uncertainty of the total vibration value ahv [m/s ²]	1,7	0,6

Type	BS60-2 11"	BS60-2plus 11"
Material number machine	5100051580	5100030604
* The actual operating speed depends on numerous operating parameters and may differ from the rated speed.		

Type	BS70-2 11"	BS70-2plus 11"
Material number machine	5100030607	5100030609
Material number engine	5100008899	5100009016
Number of strokes [1/min]	687	687
Impact force [kN]	20	20
Forward travel [m/min]	8,9	8,9
Length [mm]	673	687
Width [mm]	343	343
Height [mm]	965	965
Length (Ramming shoe) [mm]	340	340
Width (Ramming shoe) [mm]	280	280
Operating weight [kg]	74	74
Rated output [kW]	2	2
Rated speed [1/min]	4400	4400
Standard	ISO 3046-1	ISO 3046-1
Engine type	WM80	WM80
Oil specifications (Ramming system)	SAE 10W-40	SAE 10W-40
Oil volume (Ramming system) [l]	0,9	0,9
Operating temperature range [°C]	-10 – +40	-10 – +40
Storage temperature range [°C]	-30 – +50	-30 – +50
Sound pressure level LpA [dB(A)]	93	93
Sound power level LWa measured [dB(A)]	105	105
Sound power level LWa guaranteed [dB(A)]	108	108
Vibration total value ahv [m/s ²]	6,9	7,0
Measurement uncertainty of the total vibration value ahv [m/s ²]	0,8	0,6
* The actual operating speed depends on numerous operating parameters and may differ from the rated speed.		

13.4 Combustion engine

Engine manufacturer	Wacker Neuson
Material number engine	5100008899
Engine type	WM80
Combustion processes	two-stroke
Cooling	Air
Cylinder	1
Cubic capacity [cm ³]	80
Fuel type	Oil/gasoline mixture; oil/alkylate gasoline mixture
Fuel type	Oil/gasoline mixture
Fuel mixing ratio	1:50

Engine manufacturer	Wacker Neuson
Material number engine	5100008899
Fuel consumption [l/h]	1,1
Tank volume [l]	2,9
Oil specification	ISO-L EG C, ISO-L EG D, JASO FC, JASO FD
Output max. [kW]	2,2
RPM [1/min]	4400
Standard	ISO 3046-1
Exhaust-emission level	EU Stage V, US Phase 3
CO2 emission* [g/kWh]	1113
Exhaust gas aftertreatment	Oxidation catalyst
Spark plug type	RL86C
Electrode gap [mm]	0,5 - 0,8
* Determined value of the CO2 emission during engine certification without consideration of the applications on the machine.	

Engine manufacturer	Wacker Neuson
Material number engine	5100009016
Engine type	WM80
Combustion processes	two-stroke
Cooling	Air
Cylinder	1
Cubic capacity [cm ³]	80
Fuel type	Oil/gasoline mixture
Fuel mixing ratio	1:50
Fuel consumption [l/h]	1,0
Tank volume [l]	2,9
Oil specification	ISO-L EG C, ISO-L EG D, JASO FC, JASO FD
Output max. [kW]	2,2
RPM [1/min]	4400
Standard	ISO 3046-1
Exhaust-emission level	EU Stage V, US Stage 3, CN Stage II
CO2 emission* [g/kWh]	1113
Exhaust gas aftertreatment	Oxidation catalyst
Spark plug type	QL87YC
Electrode gap [mm]	0,5 - 0,8
* Determined value of the CO2 emission during engine certification without consideration of the applications on the machine.	



**WACKER
NEUSON**
all it takes!

**Wacker Neuson Produktion GmbH &
Co. KG**

Wackerstraße 6
D-85084 Reichertshofen

Tel.: +49 8453 340-0
EMail: service-LE@wackerneuson.com
www.wackerneuson.com

Material Number: 5100056271

Language: [en]